

# THE BOATER'S GUIDE TO SUCCESSFUL REPOWERING



The First In A Series  
Of Practical Guides For  
The Recreational Boater



Published By:  
Yanmar Diesel America Corp.  
As A Service To  
The Boating Community.



## Are You Happy With Your Present Boat?

Do you like its classic looks, strong construction and good sea keeping qualities? Chances are, you like everything about it...with one exception. Anyone who has ever owned a boat for more than a few years, will readily admit that there comes a point when the possibility of replacing an engine or two becomes a very real likelihood. To some, the mere thought of replacing their tired gas guzzling engines with a pair of new, fuel efficient diesels sounds great. To others, the task may appear somewhat daunting. After all, repowering any inboard is a little more involved than simply dropping a new outboard on your transom.

## A Practical Approach

Engine selection is indeed important. However, this guide was written to provide you with a solid understanding of those things to be considered beyond engine size, horsepower and brand. It was published as a "how to" guide covering everything from evaluating cost vs. the value derived, to selecting an experienced and reputable installer. In spite of its perceived complexity, repowering doesn't have to be a hassle.

## Engine Reliability Is Paramount!

Marine engines must, above all else, be reliable. Engine reliability is especially important in pleasure boats, where the capability of the crew to deal with mechanical problems may not equal that of crews on commercial vessels. Today's marine engines have a long life; however, eventually either major repairs or replacement may become necessary.

## Cost Vs. Value

It may be tempting to think that the value of a boat repowered with a new engine will increase enough to fully offset the cost of the new engine and its installation. Although the boat will be worth more with a new engine, the increase in value in the used boat market may not equal your investment if you sell the boat. The same is generally true if you convert from gas to diesel. The boat's value will increase, but probably not enough to fully pay for the conversion. That said, you are considering the rebuild or repower because you want to use your boat, not sell it.

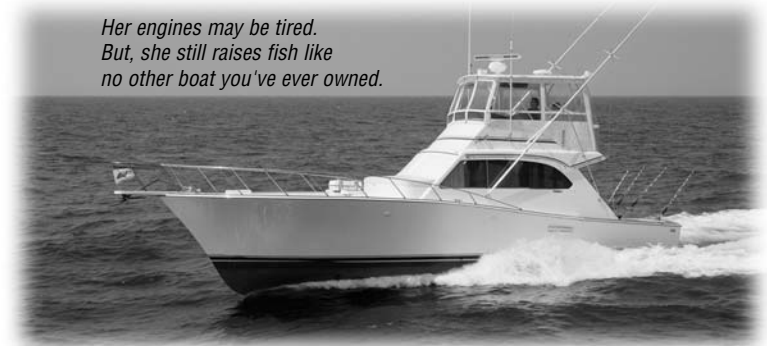

*Her engines may be tired.  
But, she still raises fish like  
no other boat you've ever owned.*

## The Rebuild / Repower Trade-Off

Although rebuilding an existing engine normally poses few challenges, the installation of a new engine usually provides significant performance and economic advantages. Many parts and accessories of a rebuilt engine – alternator, starter, water pump, for example – are usually retained, and have an uncertain further life expectancy. All parts of a new powerplant will be unused and the entire engine will carry a very valuable manufacturer's warranty. There are no hard and fast rules for deciding between rebuilding an existing engine or repowering with a new engine. However, spending more than about 40% of the cost of a new engine on a rebuild may not be a good investment.

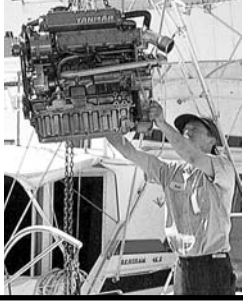

## Repowering, Getting The Job Done Right

A successful repowering project involves two equally critical decisions; selection of a qualified installer and choosing the right engine for the boat. Of the two, the selection of the installer can be the more challenging. While engines can be precisely defined by their specifications, the installation of new engines requires reliance upon the engineering judgment and the skill of those doing the work. The project must be planned carefully in conformance with applicable ABYC\* standards. The work must be done right; “good enough” won’t do. The following suggestions may help you achieve your goals in repowering your boat.

Accept bids only from prospective installers who have visited and carefully examined your boat. The prospective installer should have questioned you about the way in which you operate your vessel. The overall reputation of the yard, and in particular, their experience in installing the type of engine you have chosen, are important factors in your decision process. Ask for references, especially from owners of boats similar to yours, and if possible, for installations using the same engine family you are considering. Be sure that every item described in the technical areas identified on the following pages is enumerated on any proposal you consider. A few items, such as the practicality of converting a gasoline tank to diesel fuel, may have to remain undefined until the work begins. To the degree possible, leave nothing to chance or to “we will see about that later”.

## How Big An Engine?

While the search for an installer proceeds, you should determine the horsepower you will want in your new engine. Simply installing an engine of the same power as the existing one may not be in your best interest. Your power needs will, in part, depend on the type of boat being repowered. A displacement hull vessel is usually best served with a new engine of about the same power as used originally. Unless the boat was seriously underpowered, installing a more powerful engine will be unwise. In contrast, planing hull boats, which are very sensitive to weight, may be able to take advantage of the significant power to weight improvements made in diesel engines in the past few years. With today’s lighter engines, it is often possible to install a less powerful engine than the existing powerplant, while equaling and often exceeding existing performance. Alternatively, installing an engine similar in weight and size to the existing engine, can provide substantially more power, boosting both acceleration and top speed. However, keep in mind that a more powerful engine may require stronger engine beds, larger prop shafts and propellers, additional fuel tank capacity and reworking of the existing intake air and exhaust system.

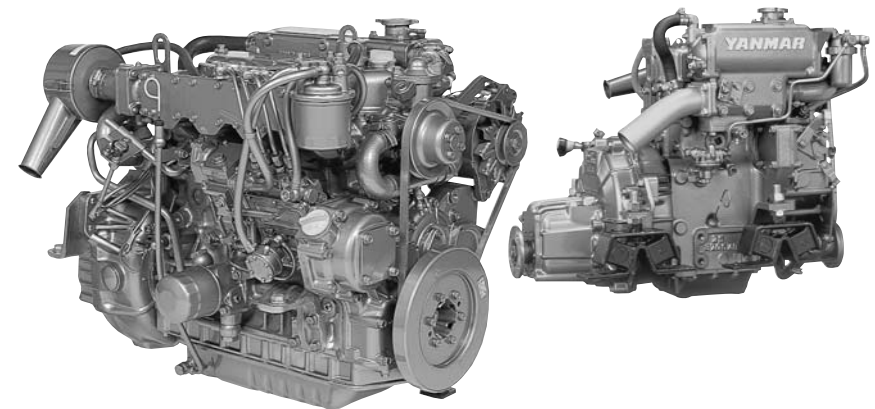

\* The American Boat & Yacht Council is dedicated to enhancing boating safety by providing standards, education and information to the recreational boating community.



## The Devil Is In The Details

A few basic considerations will help define your repowering project.

- The engine must fit in the space available.
- The weight of the engine should not be much in excess of the unit being replaced, with less weight generally desirable.
- There must be sufficient clearance around the new engine for inspection and maintenance access.

Unless the new engine can be properly mounted on the existing engine beds, new beds will have to be designed and installed. The fore and aft position of the new engine must be carefully considered. In many instances, the new engine may actually be shorter than the unit being replaced. However, replacing a vee type engine with a straight 6 can present fore and aft clearance challenges. Insist that the installation employ the engine mounts provided by or specified by the engine manufacturer. These mounts have likely been designed to minimize transfer of noise and vibration to the hull of the vessel. Using non-standard mounts in order to “improve” the mounting position of the engine may create more problems than it yields advantages. In the event your present engine installation transmits significant noise and vibration to the hull, you may wish to consider installing a drive shaft system that incorporates both a thrust bearing and CV joints as a part of your repower project.

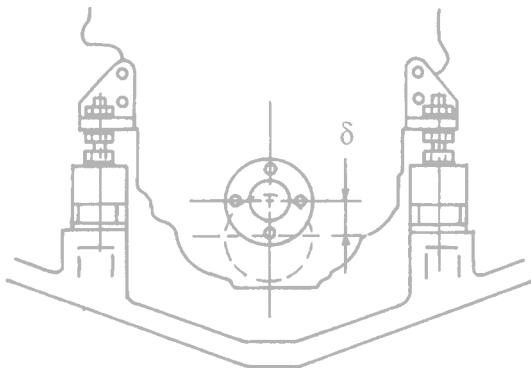

## Clean, Cool Air In, Hot Air and Exhaust Out!

It is tempting to believe that the engine compartment air intake, and heated air removal and exhaust systems used for the existing engine will suffice for the new powerplant, even if it is no more powerful than its predecessor. Unhappily, this is often not the case. No engine benefits from operating with restricted fresh air for compartment cooling and combustion. Engine power unavoidably decreases as the temperature of its combustion air increases above 77° F. Many original engine compartment designs did not adequately address these areas of concern. The exhaust system can be one of the more critical areas in a new engine installation. The diameter, and most important, the back-pressure of the existing exhaust system, must be checked to assure that they meet or exceed the requirements specified for the new engine. These precautions are especially important when a turbocharged engine is being installed. Insist on a careful check of the integrity of any existing exhaust system components that will be reused. It is far less costly to make repairs during the installation of the new engine than afterward.

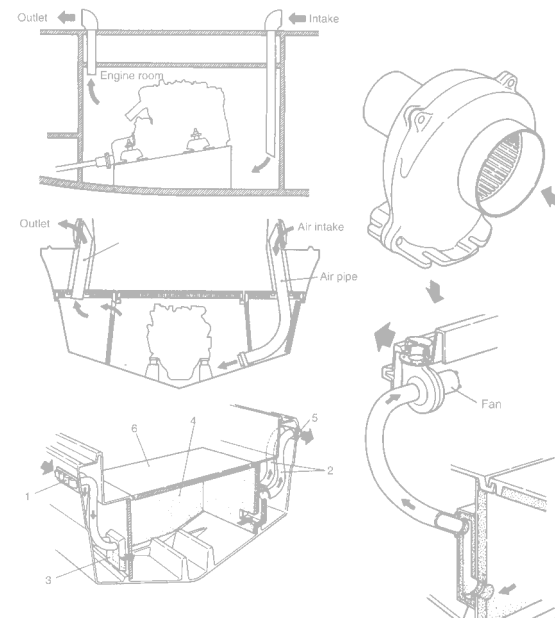



## Feed It Clean Fuel

Once assured that the new engine will be properly mounted, supplied with a sufficient flow of the coolest possible air and connected to a suitable exhaust system, consider the fuel supply, raw water cooling, electrical and instrument systems. If the boat was previously equipped with diesel power, the evaluation of the fuel system can be limited to a general check on its condition; replacing any obviously worn or deteriorated components, and if necessary flushing and cleaning the tanks. Install a fuel water separator / prefilter and priming pump, if none existed previously. Avoid the all too common mistake of installing an excessively fine filter element in the prefilter. Your new engine will have an integral final fuel filter. Use a 30 micron filter element in the prefilter. It, in combination with the typical 5 to 10 micron filter on the engine, will fully protect the fuel injection system while affording maximum filter life.

## Gasoline To Diesel Conversion

Repowering a gasoline engine boat with diesels involves some necessary additional work. The fuel system must be converted for use with diesel fuel. Not all tanks are built of material compatible with diesel fuel. A fuel return line must be installed from each engine to each tank. New fuel lines, water separator / filters and priming pumps will be needed. The diesel engine will likely produce more torque than the gas engine being replaced. Prop shafts may have to be increased in size. The rotation speed differences between gas and diesel engines may make it necessary to fit new transmissions rather than trying to use the old ones. Similarly, it may be necessary to install new propellers to ensure a proper match between the diesel's power and the boat.

## Cooling Water For The Engine, Not In The Engine

The engine's raw water intake must be equipped with a proper seacock followed by a raw water strainer, preferably one that can be opened easily, without tools, and which will reseal without the need for a new gasket. Be certain that the new engine installation design takes account of the height of the engine relative to the waterline. Engine installations that place the exhaust elbow near or below the waterline, must include a vacuum breaker / anti-siphon valve in the raw water discharge line, at a point prior to injection of cooling water into a water cooled exhaust system. This valve must be located where it can be readily checked and cleaned.

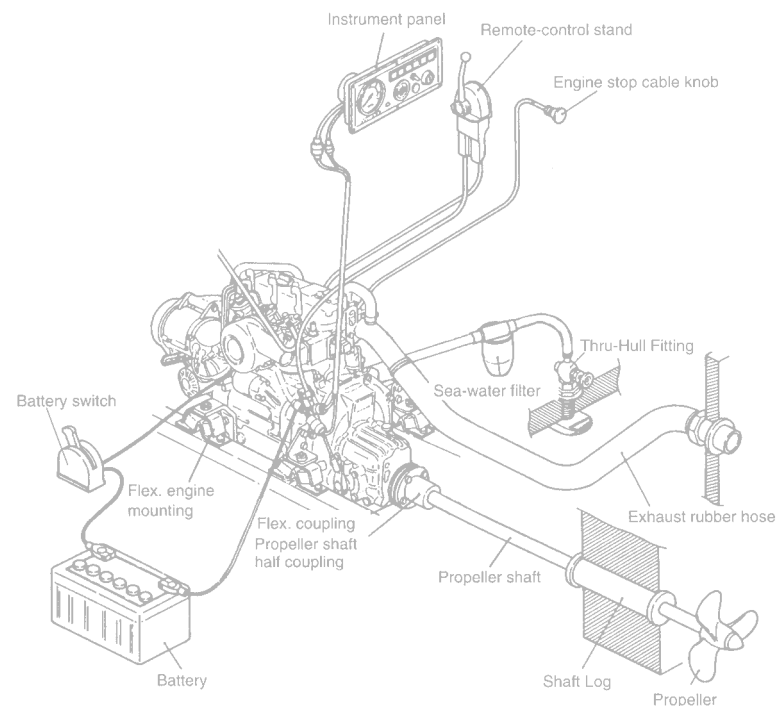



## Instruments And Controls

A new engine will be supplied with a complete instrument panel or a set of individual instruments. It is generally easier and less costly to install the new panel, rather than attempt to make the engine sensors operate existing gauges and indicators. Pay particular attention to the tachometer installation. Some engines derive engine speed information from the AC current generated in the alternator, while others such as Yanmar, take the more precise approach of monitoring the passage of gear teeth on the flywheel. Regardless of how measured, accurate rpm information will be critical in the process of selecting a propeller.

The battery charging system of a new engine will likely mate quite well with the existing electrical system. However, it is advisable to check the rated output of the alternator supplied with the engine to determine if it will cope with the vessel's requirements for DC power. Often, the installation of a new engine is accompanied by the desire to install additional engine powered equipment; an additional alternator, a refrigeration compressor, a reverse osmosis watermaker pump, etc. Check the engine manufacturer's literature for guidance in this area. Improperly applied external loads can damage the front bearing of an engine. A special mounting frame may be required to properly power external, front of engine loads.

The existing engine controls can most often be reused with the new engine. However, they must be carefully checked for wear and condition. In some cases, the engine stop control will have to be modified from manual to electric or vice versa.

## Prop Shaft And Propeller

Depending on the choice of replacement engine, it may be necessary to install a larger propeller shaft, shaft log and strut. Especially in planing hull boats, a new propeller may be required if the power or the weight of the new engine differs significantly from the one being replaced. Engines in some single engine boats are purposely installed at a slight angle from the longitudinal centerline in order to offset the propeller factor - the asymmetric thrust produced by a propeller rotating on an inclined shaft. If this is the case, be sure the new engine's rotation direction is the same as the original installation. When necessary, this can be accomplished by choosing a gear box capable of operating with the same gear ratio and efficiency in either direction.

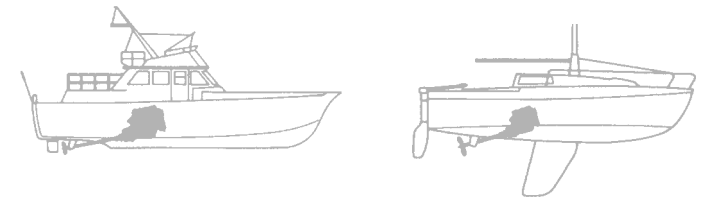

## The BIG DAY, On Water Performance Checks

A new engine installation is not complete until its performance has been checked on the water, and the operator has become familiar with the proper management of the new powerplant. The sea trial must include operation at all power levels, a careful check of cooling system operation, exhaust system performance and back-pressure, adequacy of combustion air supply and maintenance of acceptable engine compartment temperature, ability to draw from all fuel tanks, ease of starting, shifting, rpm at wide open throttle and shut down. The manufacturer's initial operating procedures must be well understood. Be sure to check with the engine manufacturer regarding operation during the initial 100 hours. Many new engines are damaged by being operated at insufficient power levels during their initial use period, when moderately high power operation is critical to proper seating of the piston rings.

---

## Check List:

- Realistic power level;** available power at maximum rpm, -200 and -400 rpm, time limits (if any) at these power levels.
- Engine size, weight, shape;** will it fit easily into the available space?
- Shaft rotation;** does it match the existing installation? If not, is there a dual direction gear box available?
- Exhaust system requirements;** compare with existing installation. Consider displacement and maximum rpm limits for both existing and new engine.
- Engine compartment design;** adequacy of fresh air supply, exhaust of heated air, noise trapping of air intakes and exhausts, improvements likely to be required / desired.
- Position of engine components relative to existing engine and constraints of engine compartment;** will extensive rerouting of hoses, cables and controls be required? Will it be possible to gain access to the engine's components for inspection and service?
- Engine controls and indicators;** can the controls and indicators for the new engine be readily integrated into the existing panels?
- Adequacy of existing fuel system;** if already diesel, is system in good condition? If power of new engine is significantly greater than that of the existing engine, will the present system hold enough fuel? If gasoline, will the existing tank material be suitable for use with diesel fuel? Can the required fuel return lines be added?



YANMAR MARINE USA  
Visit [www.yanmarmarine.com](http://www.yanmarmarine.com)

For the name of your nearest Yanmar Distributor.