

Submersible Cleaner for Fish Farming Nets NCL-SE3

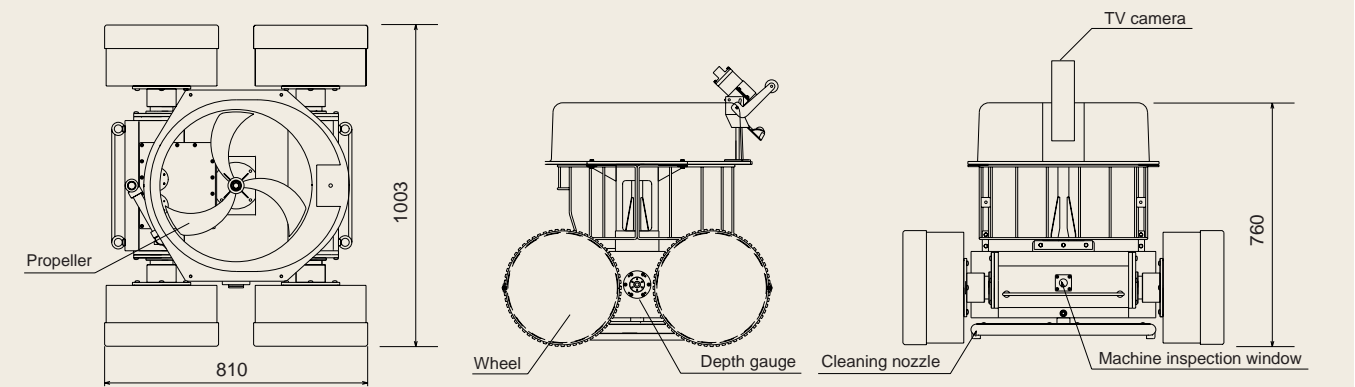

Dimensions (Units: mm)



Specifications

Model	NCL - SE3		Remarks	
Robot	Outer dimensions (mm)	L810 × W1003 × H760		
	Weight (kg)	Approx.150		
	Max. traveling speed (m/min)	12		
	Max. cleaning speed (m ² /min)	6.2(Practical cleaning speed:4.0)		
	Max. reachable depth (m)	30		
	Propeller (mm)	450		
	Wheel	Stainless steel × 4		
	Motor	DC motor with reduction gear		
	Depth gauge	Pressur sensor type × 1		
	TV camera	CCD with wide-angle lens × 1		
	Camera cable	Twist-resistant cable 40m × 1		
		Twist-resistant cable 60m,100m × 1	Option	
	Power cable	Twist-resistant cable 40m × 1		
	Twist-resistant cable 60m,100m × 1	Option		
Control cable	Twist-resistant cable 40m × 1			
	Twist-resistant cable 60m,100m × 1	Option		
High pressure hose (m)		35		
		55, 70	Option	
Control box	Outer dimensions (mm)	L200 × W500 × H605		
	Power supply	Control Power input × 1(24VDC,15A)		
Remote control box	Outer dimensions (mm)	L150 × W210 × H310		
	Indications	Depth display × 1		
	Operation equipment		Joy stick × 2	
			Speed control volume × 2	
			Operation switch × 1	
Input/Output		Robot control input/output × 1 set		
		Remote control box input/output × 1		
TV Monitor		15-inch color	*	

*Specifications are subject to change because the TV monitor is commercially obtained part.
Yanmar Co., Ltd. has acquired Patent No. 3592204 and Registered Trademark No. 4531400 for this product.



Read the operation manual carefully before use.
Conduct all periodic checks to prevent breakdowns and accidents.
Specifications and design in this catalogue are subject to change without notice.

Easily clean your nets with Saving cost, Raising High Quality fish, Easy on Environment.

Fish farming nets need to be cleaned periodically to maintain water quality and protect aquaculture fishes against disease. Yanmar's Sensui-Kun Mark III submersible cleaner is a self-propelled submersible robot that efficiently cleans underwater netting. Only one person is needed to control and operate the robot. In just a short amount of time, side and bottom of the fish farm net can be cleaned without raising net, displacing aquaculture fishes or putting people in the water, giving users tremendous labor-savings results.

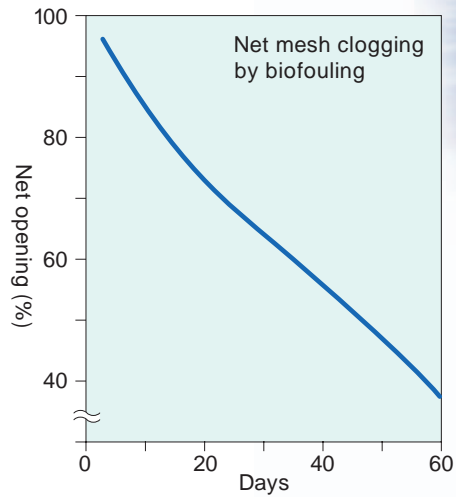

Merits of efficient net cleaning

- Prevents the proliferation of parasites because fish farming nets are kept clean.
- Anti fouling chemical and medicine for fish use can be reduced.
- Improves the flow of water through the nets and eliminates a drop of oxygen concentration in the fish farming cage, thereby preventing a decrease in feeding activity and an associated reduction in the number of aquaculture fishes in the cage.
- Prevents harm to aquaculture fishes by adhering shellfish.
- Prevents weight increases of farming net caused by biofouling to the net, hence avoiding sinking and damage of farming net cages.
- Cleaning can be done anytime it is needed.
- Reduces use of cleaning agents.

Strong cleaning action, effective cleaning by close contact

All of the water from a high pressure pump is used to ensure on-the-spot powerful cleaning. The recoil from the water jet is used to turn the propeller and keep the robot pressed against the net. Users will enjoy wonderful cleaning performance.

Easy setup and placement in fish farming cages

Allows the nets to be cleaned anytime it is needed. The robot can be fed through a small opening in bird guarding nets over the fish farming cages and into the water, making it easy to clean netting.

Easy remote control operation and monitoring of underwater operations

The robot can be guided and operated by simply operating the remote control box joysticks. And, underwater operations can be checked in real-time on a TV monitor.

Standard Specifications



Robot

Item	Specification
Robot	Body with 40m cables and 35m high pressure hose
Cables	40 (Control, power and video feed)
High pressure hose	20 A, WP-200
Control panel	Control panel, Operating panel (Manual)
Wheels	Stainless steel
Cleaning disk	Stainless steel
TV monitor	15" LCD TV
Inverter	Inverter (24V 230V)

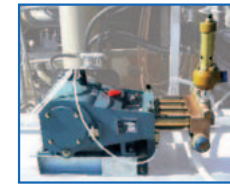

High pressure pump

Item	Specification
High pressure pump C-041H45B	Water pressure: 11.3 MPa
	Flow rate: 120.7 l/min
	Rotational speed: 460 rpm
	Required power: 30 kW (40 PS)
	Standard accessories Tools and spare packings Hose (For water intake) 2" x 3m Hose (For water overflow) 1-1/4" x 3m Strainer (For water intake)

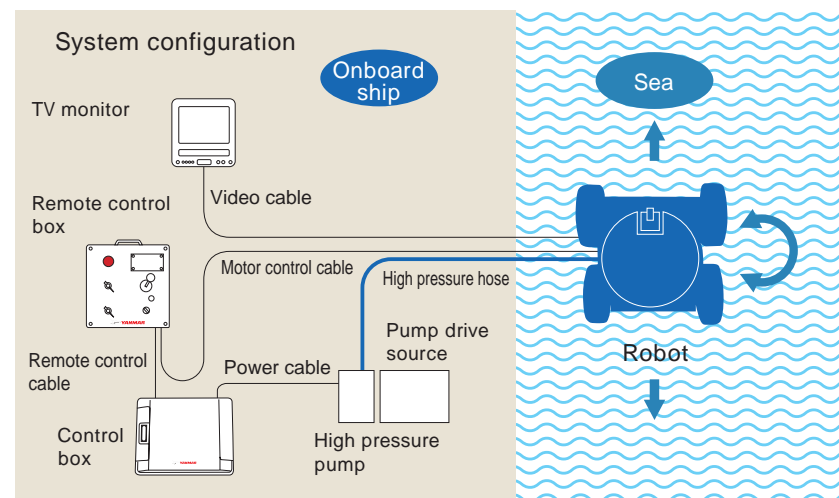
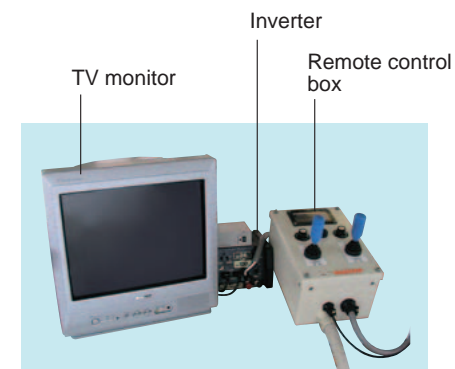

Video footage during cleaning of fiber net

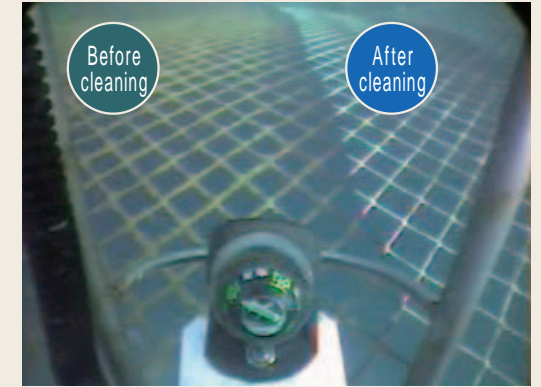

Video footage during cleaning of fiber net



Video footage during cleaning of wire mesh net



Dual cameras and monitors are available for one robot. (option) Photograph shown is in case of 2 robots.



Ship used for net cleaning